

Bufftech®

SELECT DESIRED SIZE:

4' HEIGHT X 8' WIDE

SELECT DESIRED COLOR:

DARK GRAY OAK

WALNUT BROWN

NANTUCKET GRAY

RED CEDAR

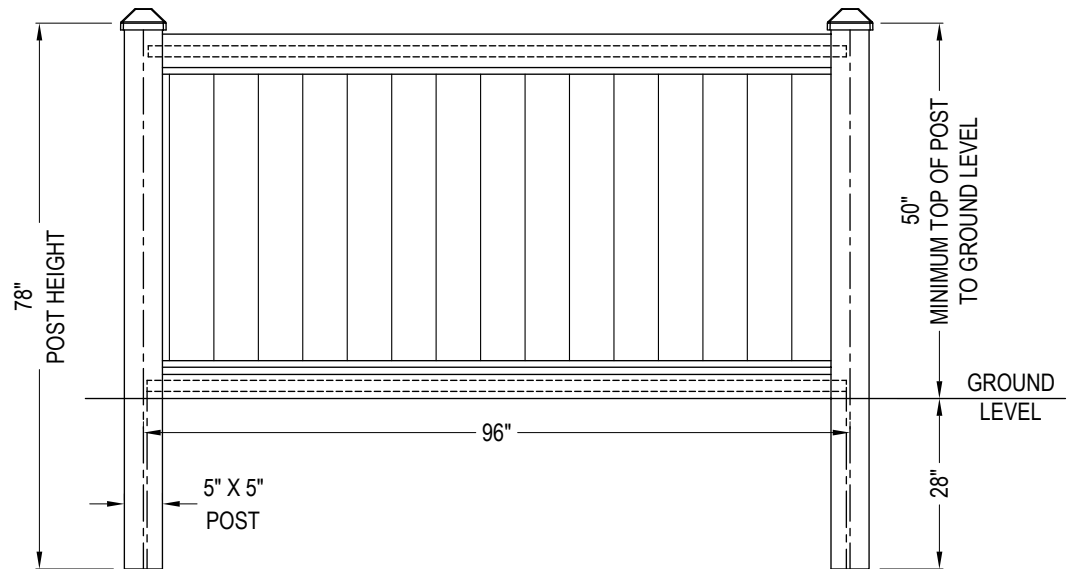

ELEVATION VIEW

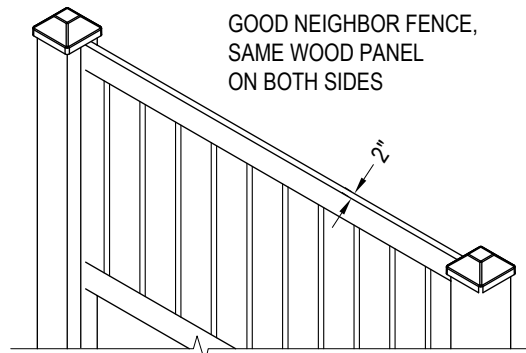

ISOMETRIC VIEW

SPECIFICATIONS

FINISH: MADE WITH LINEAR LOW DENSITY POLYETHYLENE PLASTIC (LLDPE)

ACTUAL PANEL DIMENSIONS: 48" H X 94.25" W

PANEL WEIGHT: 60 LBS

TOLERANCES: ± .5"

MANUFACTURER NOTES:

1. US PATENTS 7,478,797 / 7,635,114 FOREIGN PATENTS PENDING.

NOTES:

1. INSTALLATION TO BE COMPLETED IN ACCORDANCE WITH MANUFACTURER'S SPECIFICATIONS.
2. DO NOT SCALE DRAWING.
3. THIS DRAWING IS INTENDED FOR USE BY ARCHITECTS, ENGINEERS, CONTRACTORS, CONSULTANTS AND DESIGN PROFESSIONALS FOR PLANNING PURPOSES ONLY. THIS DRAWING MAY NOT BE USED FOR CONSTRUCTION.
4. ALL INFORMATION CONTAINED HEREIN WAS CURRENT AT THE TIME OF DEVELOPMENT BUT MUST BE REVIEWED AND APPROVED BY THE PRODUCT MANUFACTURER TO BE CONSIDERED ACCURATE.
5. CONTRACTOR'S NOTE: FOR PRODUCT AND COMPANY INFORMATION VISIT www.CADdetails.com/info AND ENTER REFERENCE NUMBER 035-110.

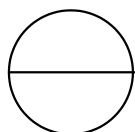

PRIVACY FENCING

(BUFFTECH) SHERWOOD FENCE PANEL - 4' H X 8' W

Bufftech®

SELECT DESIRED SIZE:

4' HEIGHT X 4' WIDE

SELECT DESIRED COLOR:

DARK GRAY OAK

WALNUT BROWN

NANTUCKET GRAY

RED CEDAR

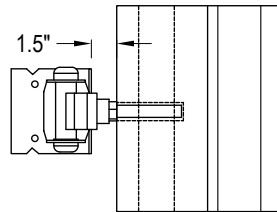

GATE HINGE THREADS INTO THE UPPER AND LOWER INSERTS IN THE GATE METAL FRAME LEAVING ABOUT 1.5" FROM THE EDGE OF THE GATE TO THE GATE POST

HINGE DETAIL

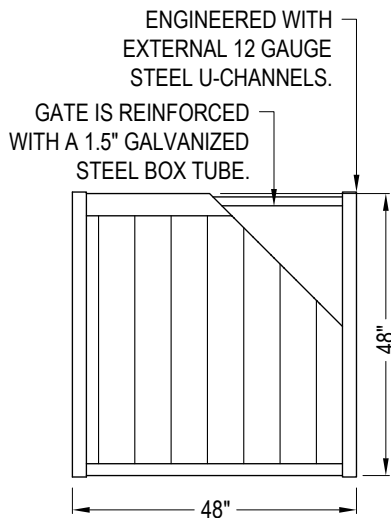

ACTUAL GATE DIMENSIONS

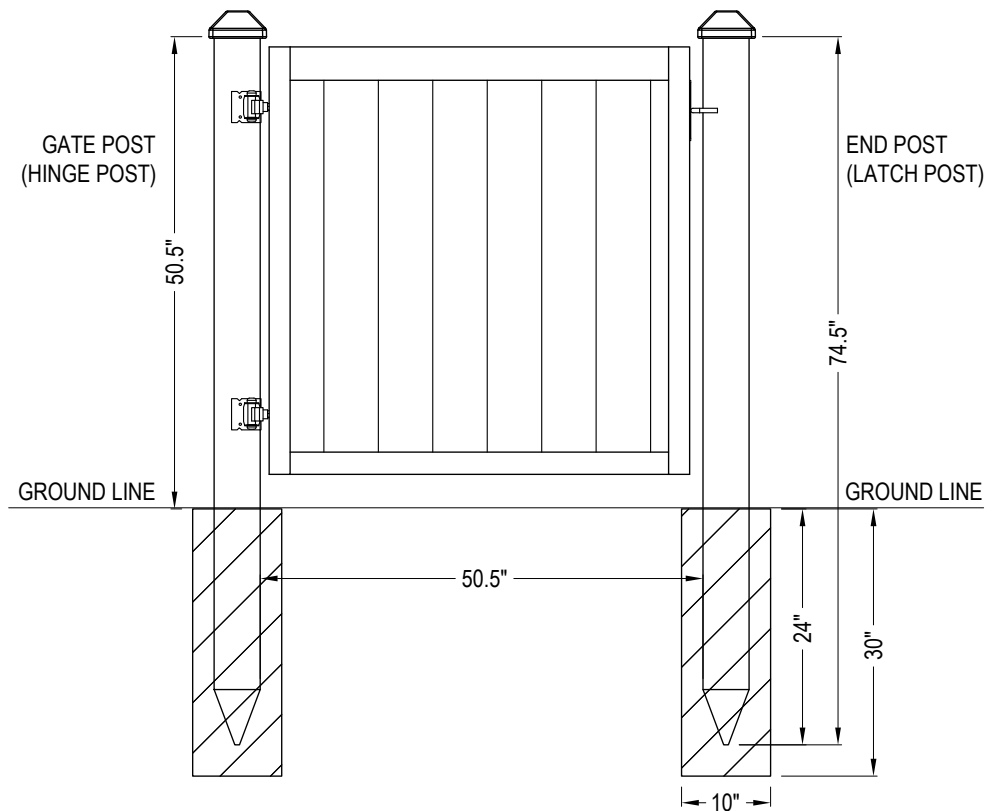

ELEVATION VIEW

NOTES:

1. INSTALLATION TO BE COMPLETED IN ACCORDANCE WITH MANUFACTURER'S SPECIFICATIONS.
2. DO NOT SCALE DRAWING.
3. THIS DRAWING IS INTENDED FOR USE BY ARCHITECTS, ENGINEERS, CONTRACTORS, CONSULTANTS AND DESIGN PROFESSIONALS FOR PLANNING PURPOSES ONLY. THIS DRAWING MAY NOT BE USED FOR CONSTRUCTION.
4. ALL INFORMATION CONTAINED HEREIN WAS CURRENT AT THE TIME OF DEVELOPMENT BUT MUST BE REVIEWED AND APPROVED BY THE PRODUCT MANUFACTURER TO BE CONSIDERED ACCURATE.
5. CONTRACTOR'S NOTE: FOR PRODUCT AND COMPANY INFORMATION VISIT www.CADdetails.com/info AND ENTER REFERENCE NUMBER 035-114.

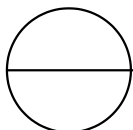

PRIVACY GATES

(BUFFTECH) SHERWOOD GATE - 4' H X 4' W

Bufftech®

SELECT DESIRED SIZE:

8' HEIGHT X 8' WIDE (TWO STACKED PANELS)

SELECT DESIRED COLOR:

DARK GRAY OAK

WALNUT BROWN

NANTUCKET GRAY

RED CEDAR

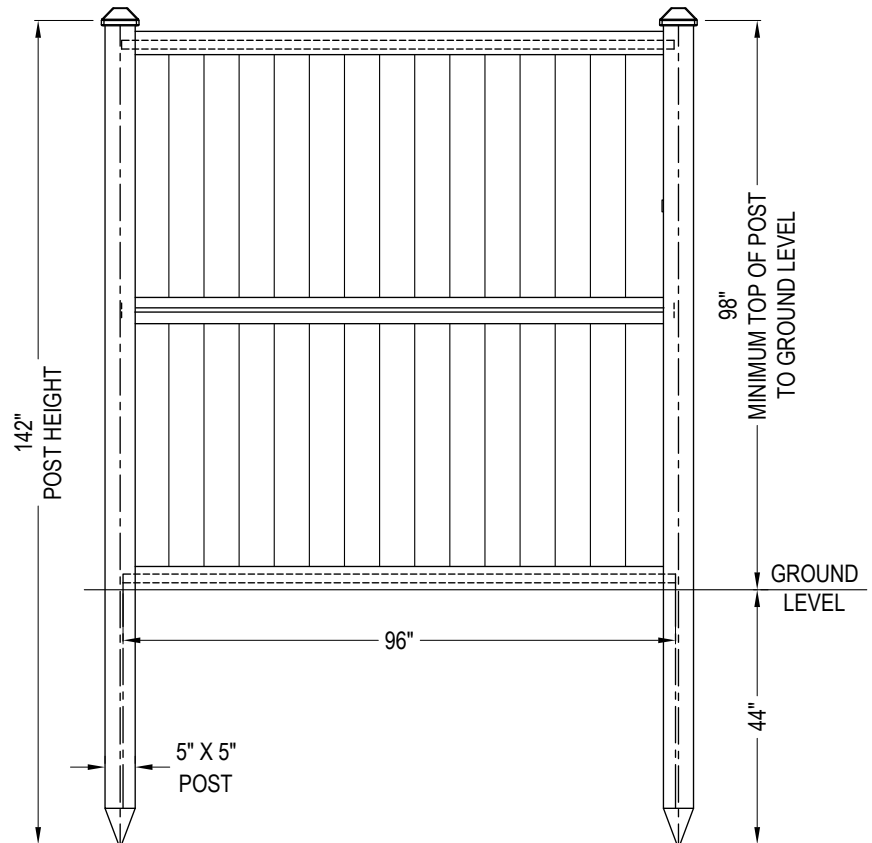
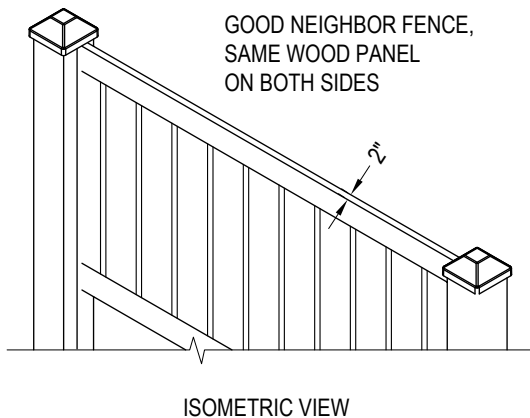

SPECIFICATIONS

FINISH: MADE WITH LINEAR LOW DENSITY POLYETHYLENE PLASTIC (LLDPE)

ACTUAL PANEL DIMENSIONS: 48" H X 94.25" W

PANEL WEIGHT: 60 LBS

TOLERANCES: ± .5"

MANUFACTURER NOTES:

1. US PATENTS 7,478,797 / 7,635,114 FOREIGN PATENTS PENDING.

NOTES:

1. INSTALLATION TO BE COMPLETED IN ACCORDANCE WITH MANUFACTURER'S SPECIFICATIONS.
2. DO NOT SCALE DRAWING.
3. THIS DRAWING IS INTENDED FOR USE BY ARCHITECTS, ENGINEERS, CONTRACTORS, CONSULTANTS AND DESIGN PROFESSIONALS FOR PLANNING PURPOSES ONLY. THIS DRAWING MAY NOT BE USED FOR CONSTRUCTION.
4. ALL INFORMATION CONTAINED HEREIN WAS CURRENT AT THE TIME OF DEVELOPMENT BUT MUST BE REVIEWED AND APPROVED BY THE PRODUCT MANUFACTURER TO BE CONSIDERED ACCURATE.
5. CONTRACTOR'S NOTE: FOR PRODUCT AND COMPANY INFORMATION VISIT www.CADdetails.com/info AND ENTER REFERENCE NUMBER 035-112.

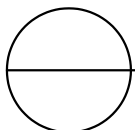

PRIVACY FENCING

(BUFFTECH) SHERWOOD FENCE PANEL - 8' H X 8' W (TWO STACKED PANELS)

Bufftech®

SELECT DESIRED SIZE:

8' HEIGHT X 4' WIDE

SELECT DESIRED COLOR:

DARK GRAY OAK

WALNUT BROWN

NANTUCKET GRAY

RED CEDAR

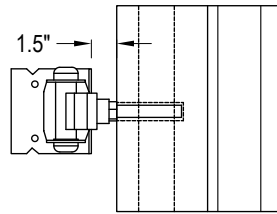

GATE HINGE THREADS INTO THE UPPER AND LOWER INSERTS IN THE GATE METAL FRAME LEAVING ABOUT 1.5" FROM THE EDGE OF THE GATE TO THE GATE POST

HINGE DETAIL

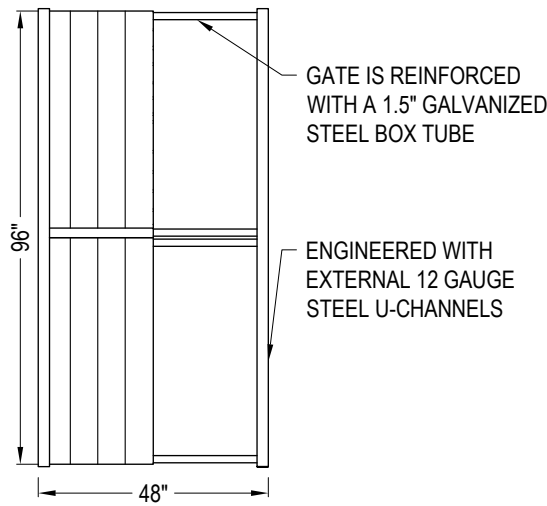

ACTUAL GATE DIMENSIONS

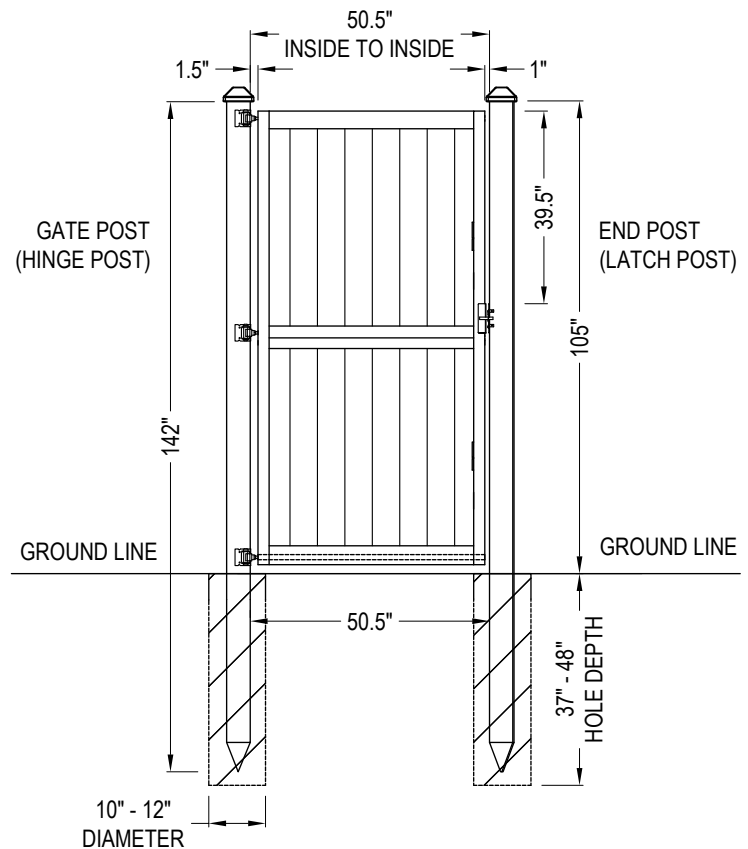

ELEVATION VIEW

SPECIFICATIONS

FINISH: MADE WITH LINEAR LOW DENSITY POLYETHYLENE PLASTIC (LLDPE)

PANEL WEIGHT: 110 LBS

TOLERANCES: ± .5"

MANUFACTURER NOTES:

1. US PATENTS 7,478,797 / 7,635,114 FOREIGN PATENTS PENDING.

NOTES:

1. INSTALLATION TO BE COMPLETED IN ACCORDANCE WITH MANUFACTURER'S SPECIFICATIONS.
2. DO NOT SCALE DRAWING.
3. THIS DRAWING IS INTENDED FOR USE BY ARCHITECTS, ENGINEERS, CONTRACTORS, CONSULTANTS AND DESIGN PROFESSIONALS FOR PLANNING PURPOSES ONLY. THIS DRAWING MAY NOT BE USED FOR CONSTRUCTION.
4. ALL INFORMATION CONTAINED HEREIN WAS CURRENT AT THE TIME OF DEVELOPMENT BUT MUST BE REVIEWED AND APPROVED BY THE PRODUCT MANUFACTURER TO BE CONSIDERED ACCURATE.
5. CONTRACTOR'S NOTE: FOR PRODUCT AND COMPANY INFORMATION VISIT www.CADdetails.com/info AND ENTER REFERENCE NUMBER 035-115.

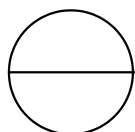

PRIVACY GATES

(BUFFTECH) SHERWOOD GATE - 8' H X 4' W

Bufftech®

SELECT DESIRED SIZE:

6' HEIGHT X 6' WIDE

SELECT DESIRED COLOR:

DARK GRAY OAK

WALNUT BROWN

NANTUCKET GRAY

RED CEDAR

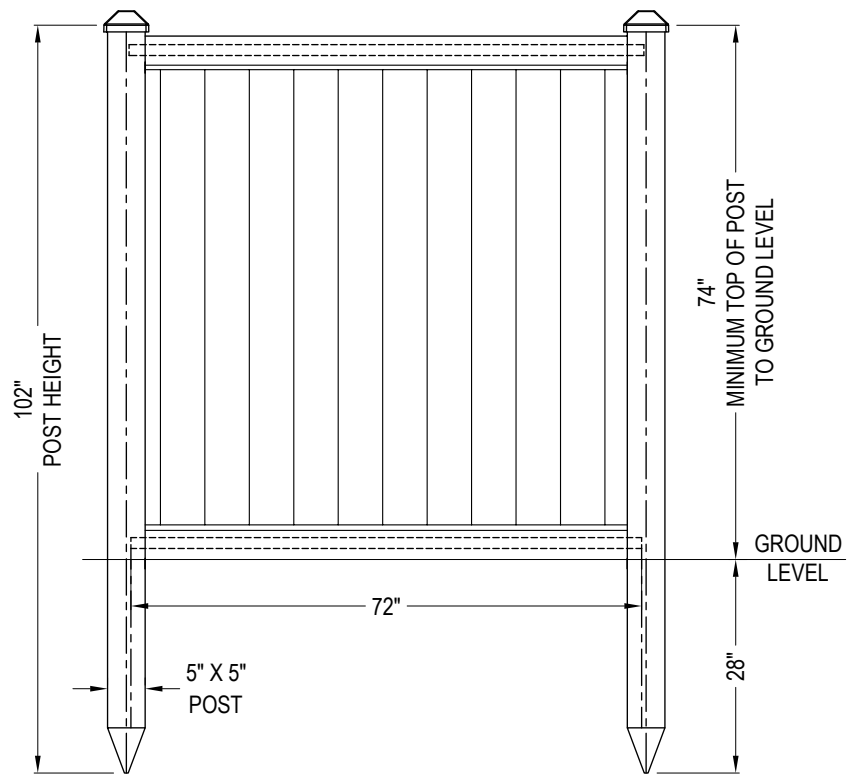
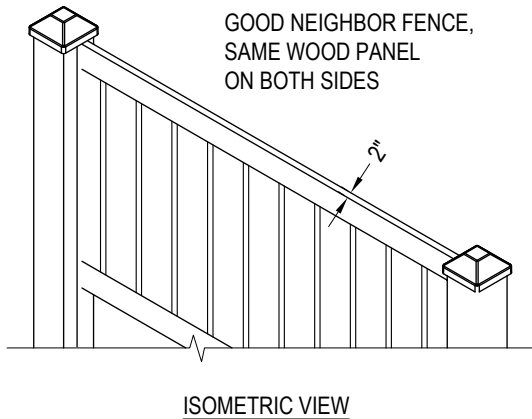

SPECIFICATIONS

FINISH: MADE WITH LINEAR LOW DENSITY POLYETHYLENE PLASTIC (LLDPE)

ACTUAL PANEL DIMENSIONS: 72" H X 69.75" W

PANEL WEIGHT: 56 LBS

TOLERANCES: ± .5"

MANUFACTURER NOTES:

1. US PATENTS 7,478,797 / 7,635,114 FOREIGN PATENTS PENDING.

NOTES:

1. INSTALLATION TO BE COMPLETED IN ACCORDANCE WITH MANUFACTURER'S SPECIFICATIONS.
2. DO NOT SCALE DRAWING.
3. THIS DRAWING IS INTENDED FOR USE BY ARCHITECTS, ENGINEERS, CONTRACTORS, CONSULTANTS AND DESIGN PROFESSIONALS FOR PLANNING PURPOSES ONLY. THIS DRAWING MAY NOT BE USED FOR CONSTRUCTION.
4. ALL INFORMATION CONTAINED HEREIN WAS CURRENT AT THE TIME OF DEVELOPMENT BUT MUST BE REVIEWED AND APPROVED BY THE PRODUCT MANUFACTURER TO BE CONSIDERED ACCURATE.
5. CONTRACTOR'S NOTE: FOR PRODUCT AND COMPANY INFORMATION VISIT www.CADdetails.com/info AND ENTER REFERENCE NUMBER 035-111.

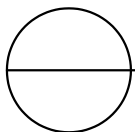

PRIVACY FENCING

(BUFFTECH) SHERWOOD FENCE PANEL - 6' H X 6' W

Bufftech®

SELECT DESIRED SIZE:

- 6' HEIGHT X 3' WIDE
- 6' HEIGHT X 4' WIDE
- 6' HEIGHT X 5' WIDE

SELECT DESIRED COLOR:

- DARK GRAY GRANITE
- WALNUT BROWN
- NANTUCKET GRAY
- RED CEDAR

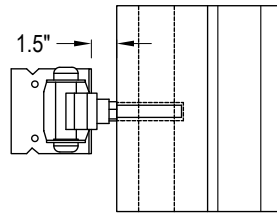

GATE HINGE THREADS INTO THE UPPER AND LOWER INSERTS IN THE GATE METAL FRAME LEAVING ABOUT 1.5" FROM THE EDGE OF THE GATE TO THE GATE POST

HINGE DETAIL

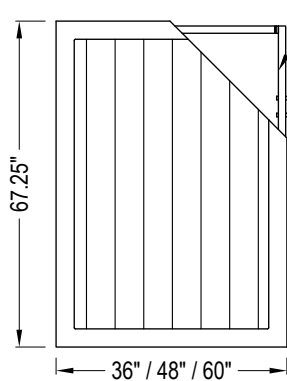

ACTUAL GATE DIMENSIONS

GATE IS REINFORCED WITH A 1.5" GALVANIZED STEEL BOX TUBE

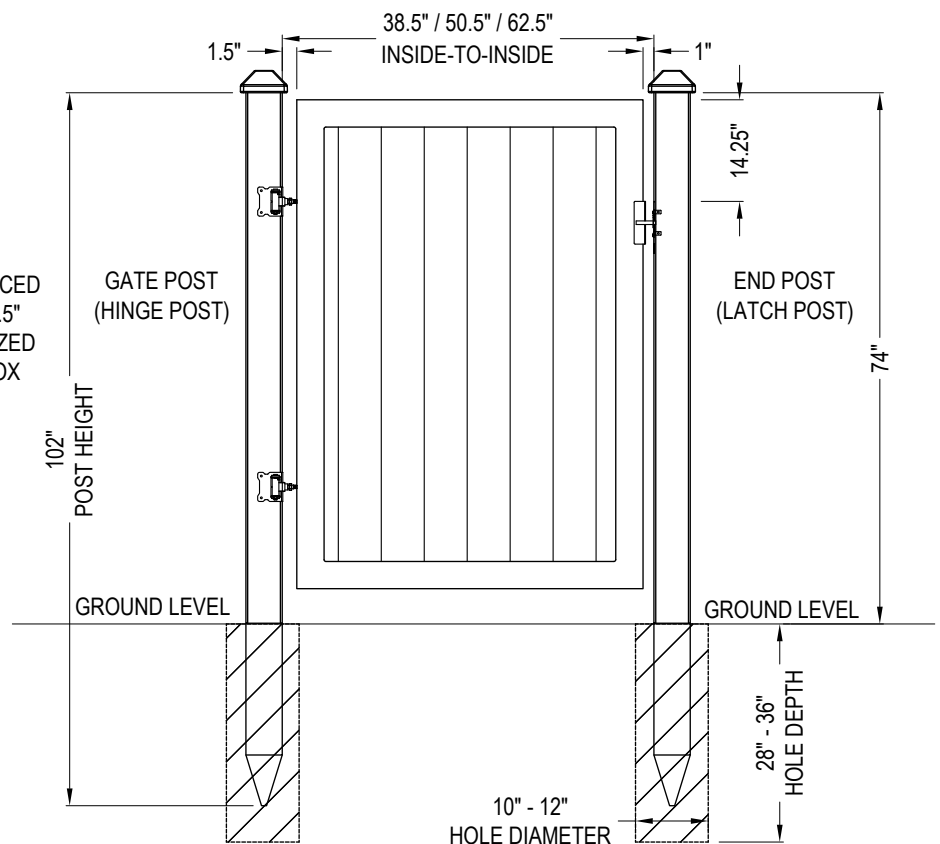

ELEVATION VIEW

SPECIFICATIONS

FINISH: MADE WITH LINEAR LOW DENSITY POLYETHYLENE PLASTIC (LLDPE)

PANEL WEIGHT: 67 LBS

TOLERANCES: ± .5"

MANUFACTURER NOTES:

1. US PATENTS 7,478,797 / 7,635,114 FOREIGN PATENTS PENDING.

NOTES:

1. INSTALLATION TO BE COMPLETED IN ACCORDANCE WITH MANUFACTURER'S SPECIFICATIONS.
2. DO NOT SCALE DRAWING.
3. THIS DRAWING IS INTENDED FOR USE BY ARCHITECTS, ENGINEERS, CONTRACTORS, CONSULTANTS AND DESIGN PROFESSIONALS FOR PLANNING PURPOSES ONLY. THIS DRAWING MAY NOT BE USED FOR CONSTRUCTION.
4. ALL INFORMATION CONTAINED HEREIN WAS CURRENT AT THE TIME OF DEVELOPMENT BUT MUST BE REVIEWED AND APPROVED BY THE PRODUCT MANUFACTURER TO BE CONSIDERED ACCURATE.
5. CONTRACTOR'S NOTE: FOR PRODUCT AND COMPANY INFORMATION VISIT www.CADdetails.com/info AND ENTER REFERENCE NUMBER 035-118.

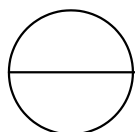

PRIVACY GATES

(BUFFTECH) SHERWOOD GATES 70 X 36, 48, 60

Bufftech®

SELECT DESIRED SIZE:

6' HEIGHT X 6' WIDE

SELECT DESIRED COLOR:

DARK GRAY OAK

WALNUT BROWN

NANTUCKET GRAY

RED CEDAR

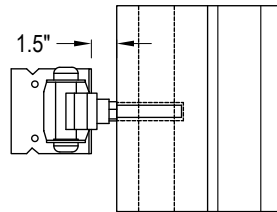

GATE HINGE THREADS INTO THE UPPER AND LOWER INSERTS IN THE GATE METAL FRAME LEAVING ABOUT 1.5" FROM THE EDGE OF THE GATE TO THE GATE POST

HINGE DETAIL

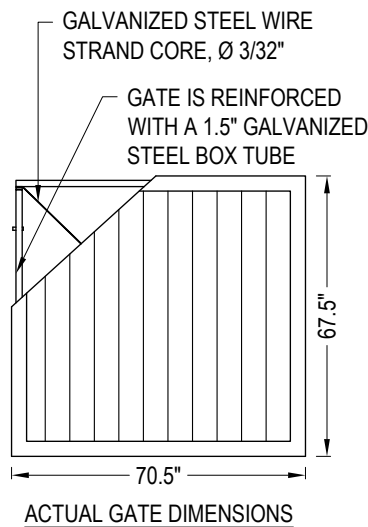

ACTUAL GATE DIMENSIONS

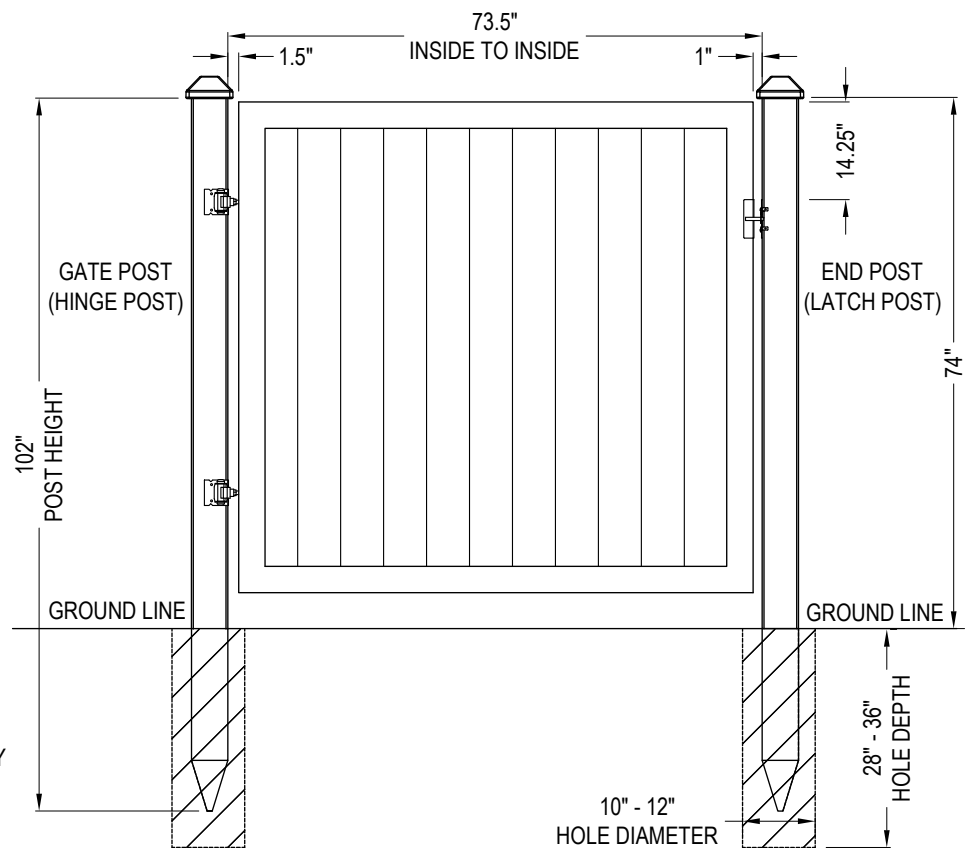

ELEVATION VIEW

SPECIFICATIONS

FINISH: MADE WITH LINEAR LOW DENSITY POLYETHYLENE PLASTIC (LLDPE)

PANEL WEIGHT: 67 LBS

TOLERANCES: ± .5"

MANUFACTURER NOTES:

1. US PATENTS 7,478,797 / 7,635,114 FOREIGN PATENTS PENDING.

NOTES:

1. INSTALLATION TO BE COMPLETED IN ACCORDANCE WITH MANUFACTURER'S SPECIFICATIONS.
2. DO NOT SCALE DRAWING.
3. THIS DRAWING IS INTENDED FOR USE BY ARCHITECTS, ENGINEERS, CONTRACTORS, CONSULTANTS AND DESIGN PROFESSIONALS FOR PLANNING PURPOSES ONLY. THIS DRAWING MAY NOT BE USED FOR CONSTRUCTION.
4. ALL INFORMATION CONTAINED HEREIN WAS CURRENT AT THE TIME OF DEVELOPMENT BUT MUST BE REVIEWED AND APPROVED BY THE PRODUCT MANUFACTURER TO BE CONSIDERED ACCURATE.
5. CONTRACTOR'S NOTE: FOR PRODUCT AND COMPANY INFORMATION VISIT www.CADdetails.com/info AND ENTER REFERENCE NUMBER 035-120.

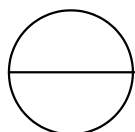

PRIVACY GATES

(BUFFTECH) SHERWOOD GATE - 6' H X 6' W