

RESIDENTIAL
5/8" PICKET

4' H x 6' W • FLAT TOP 3-RAIL
1" RAIL • 2" POSTS

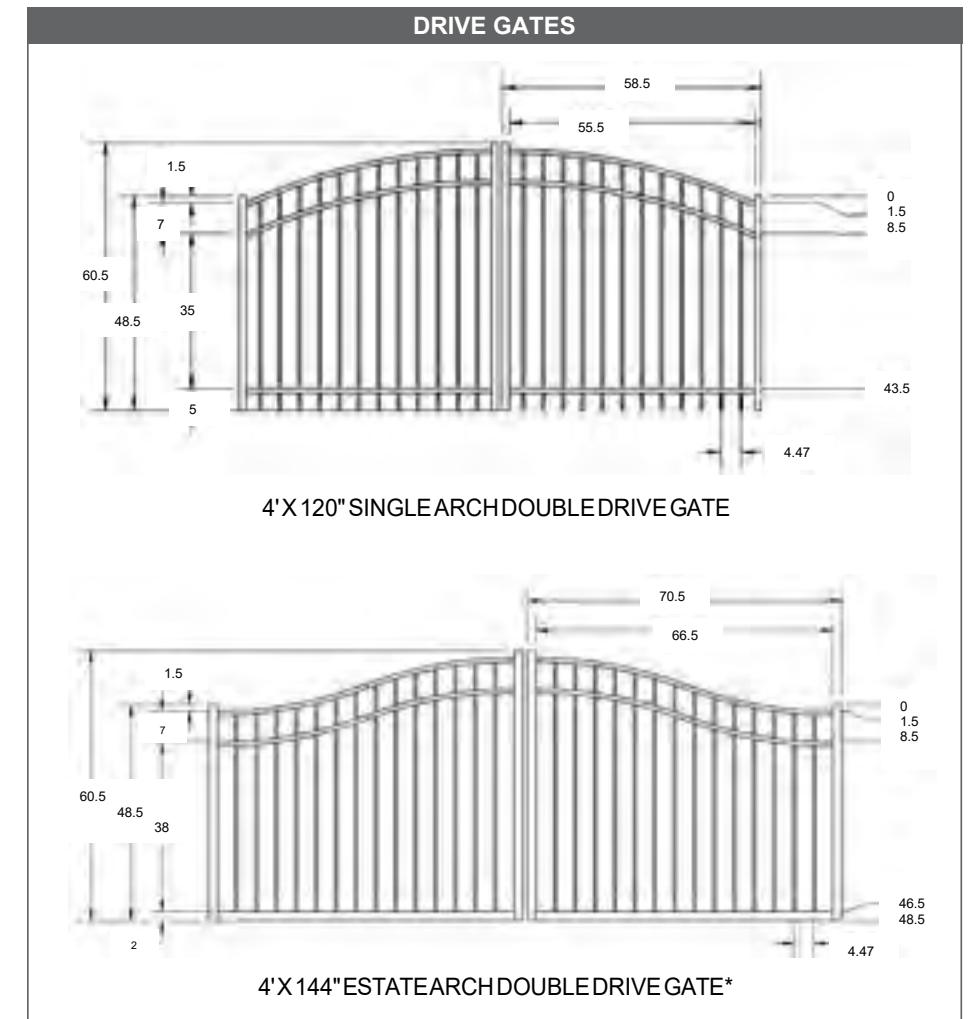
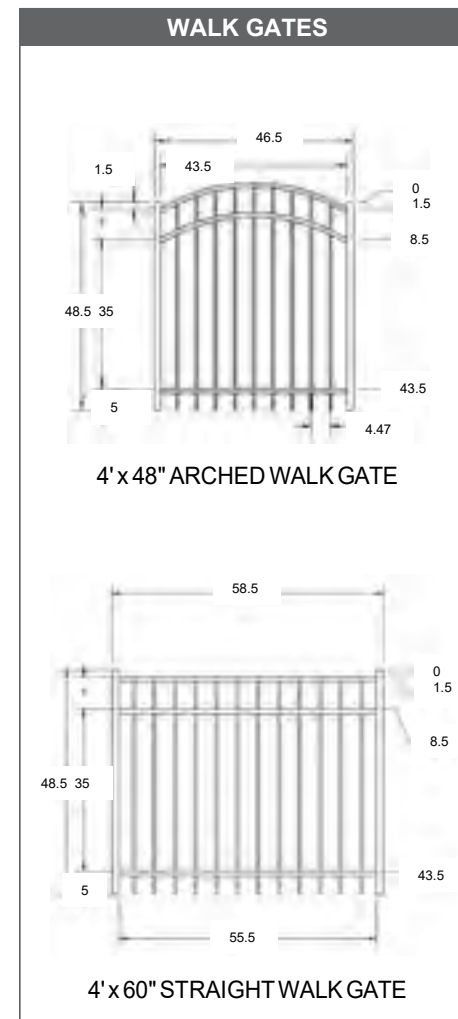
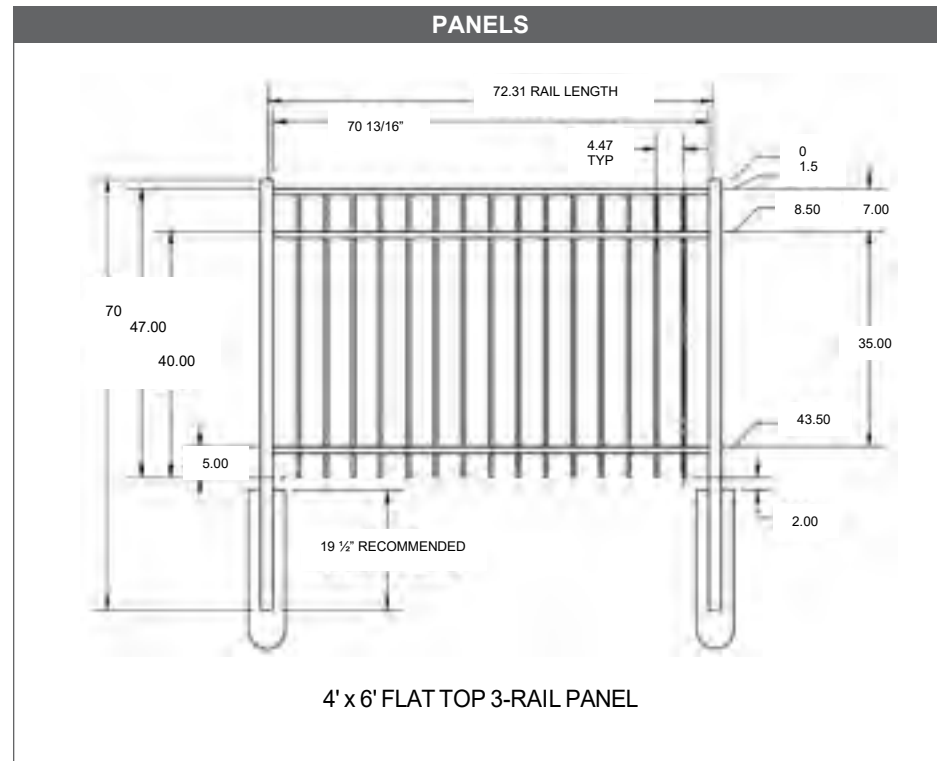

RESIDENTIAL
5/8" PICKET

4' H x 6' W • FLAT TOP 3-RAIL (FLUSH BOTTOM)

1" RAIL • 2" POSTS

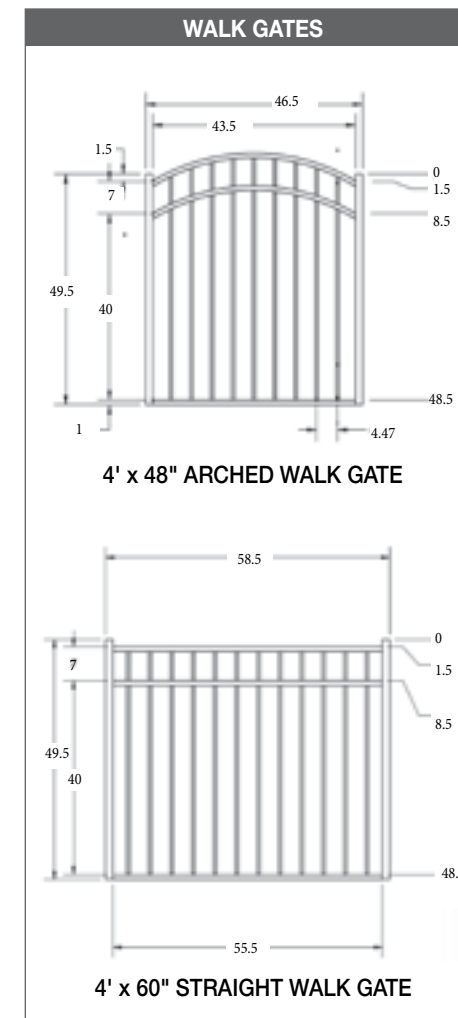
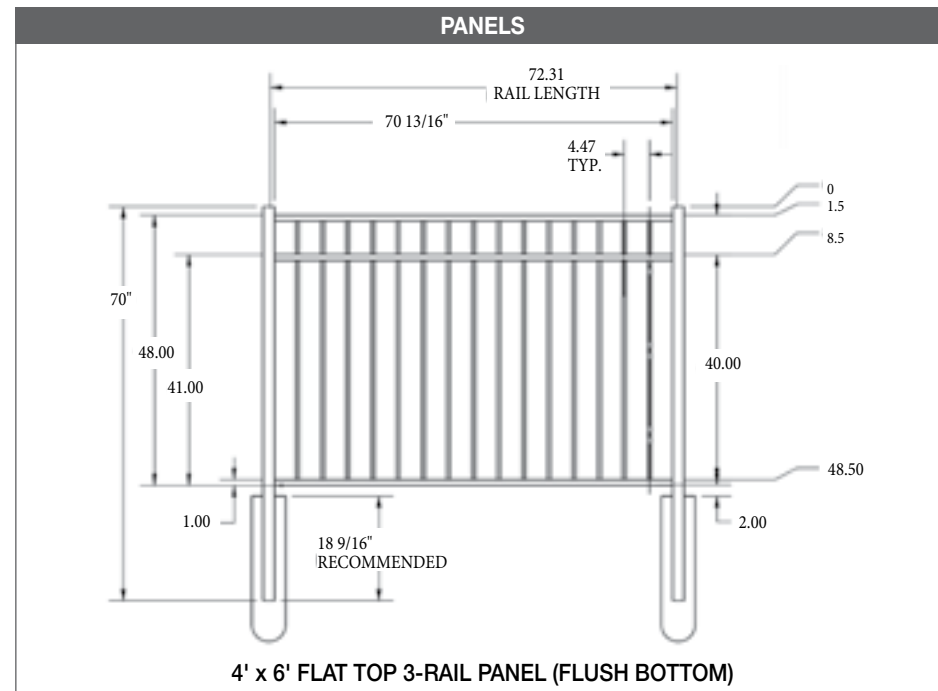

RESIDENTIAL
5/8" PICKET

4 1/2' H x 6' W • FLAT TOP 3-RAIL (FLUSH BOTTOM)
1" RAIL • 2" POSTS

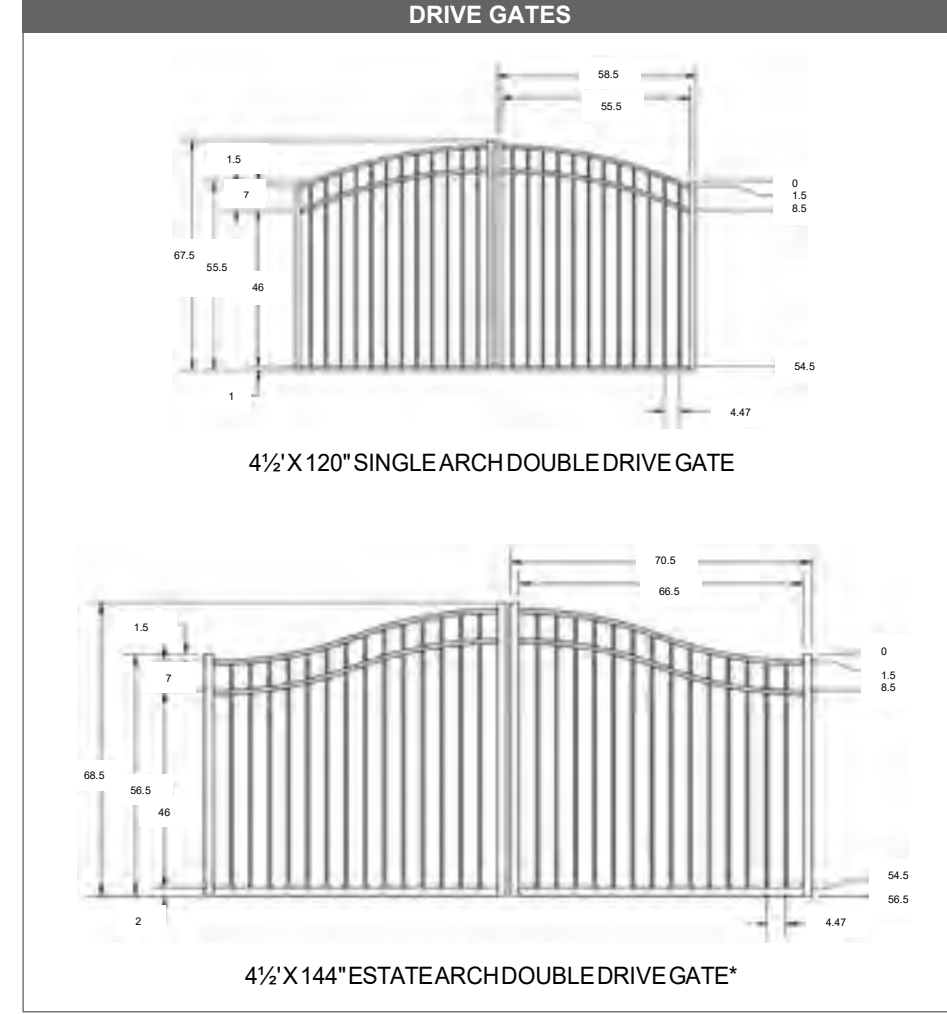
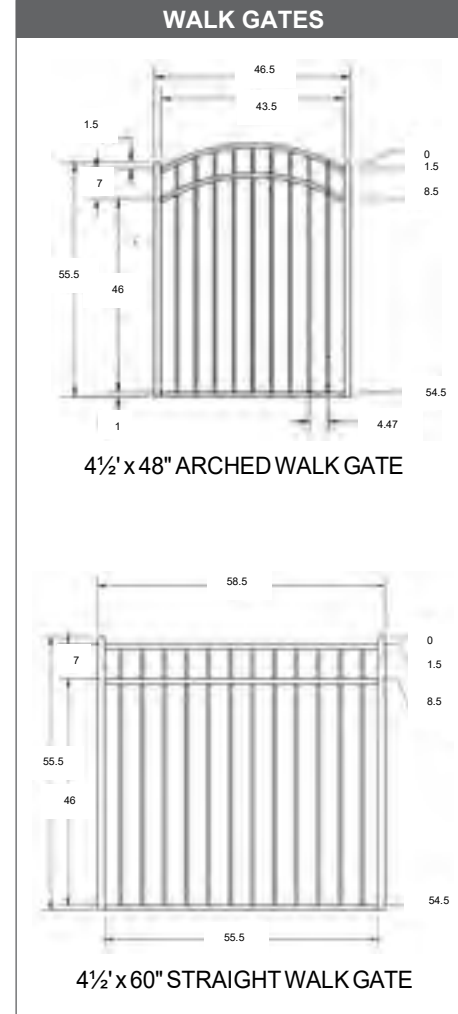
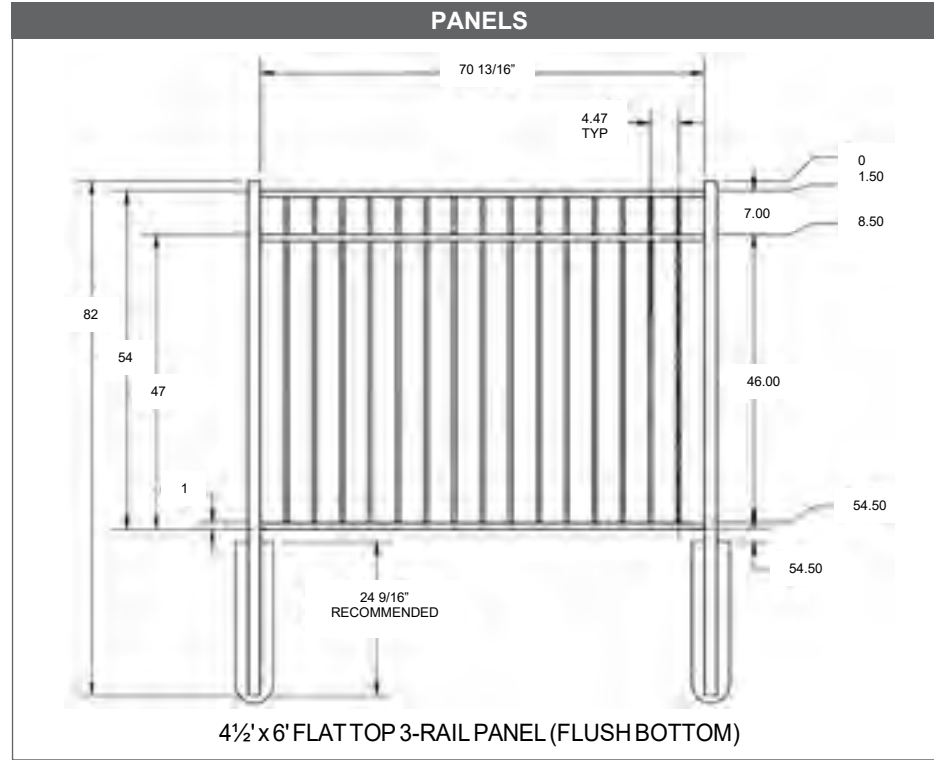

RESIDENTIAL
5/8" PICKET

5' H x 6' W • FLAT TOP 3-RAIL
1" RAIL • 2" POSTS

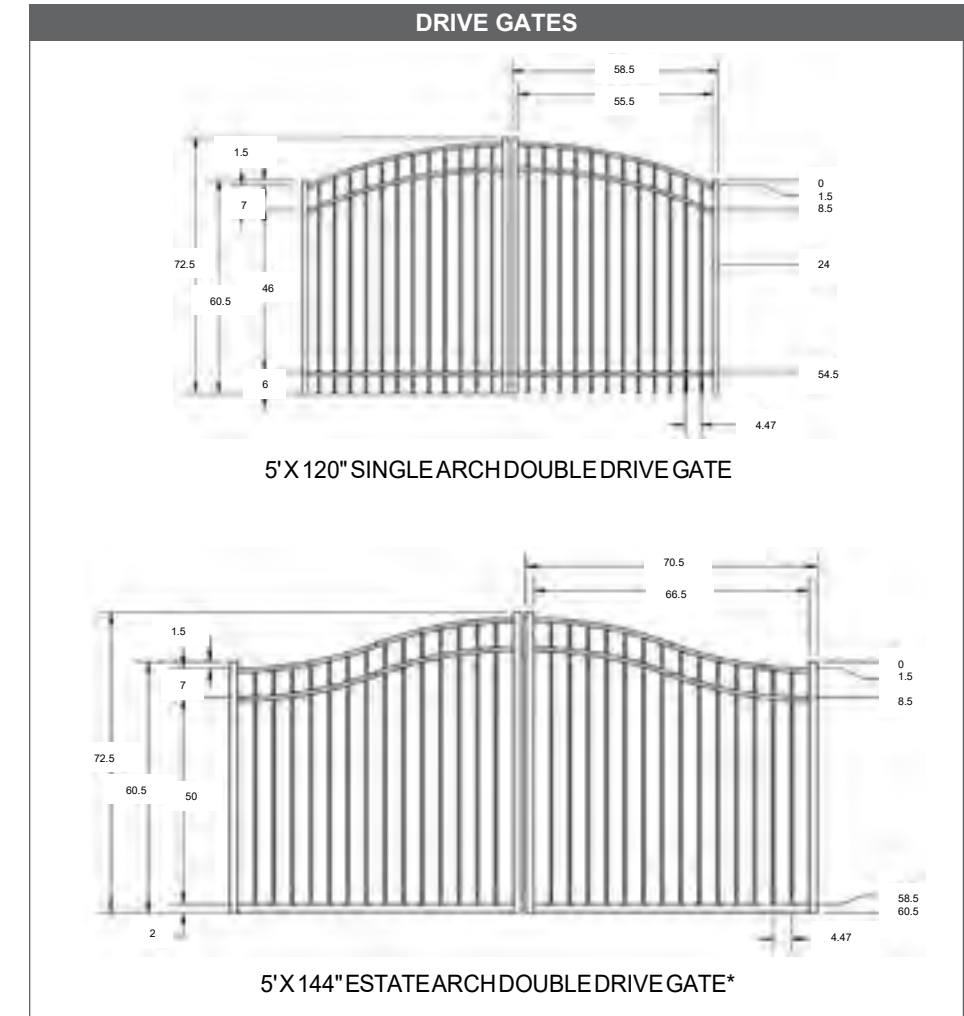
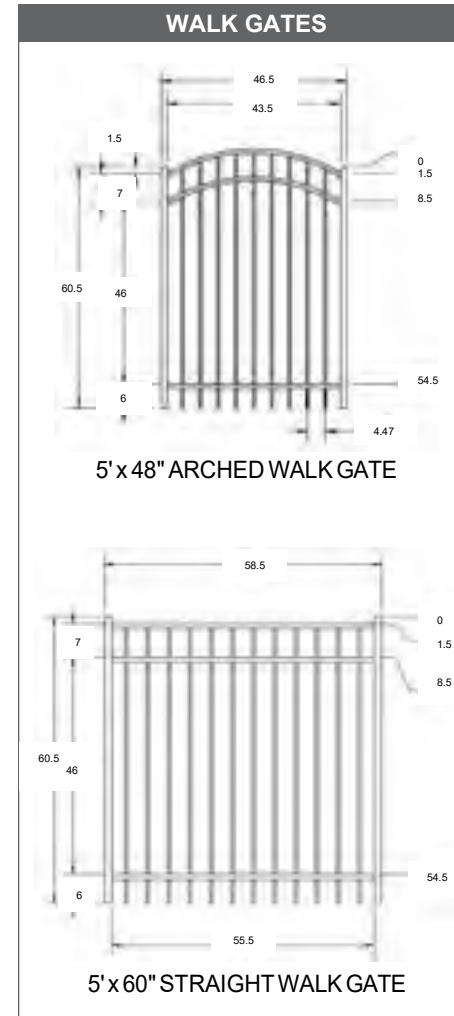
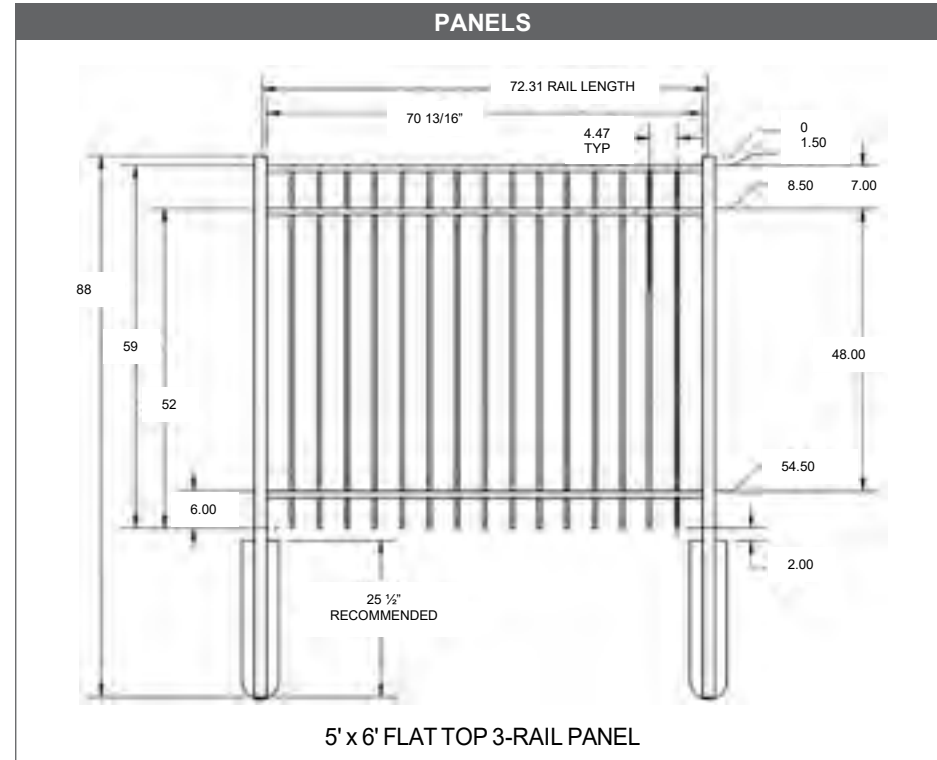

RESIDENTIAL
5/8" PICKET

6' H x 6' W • FLAT TOP 4-RAIL
1" RAIL • 2" POSTS

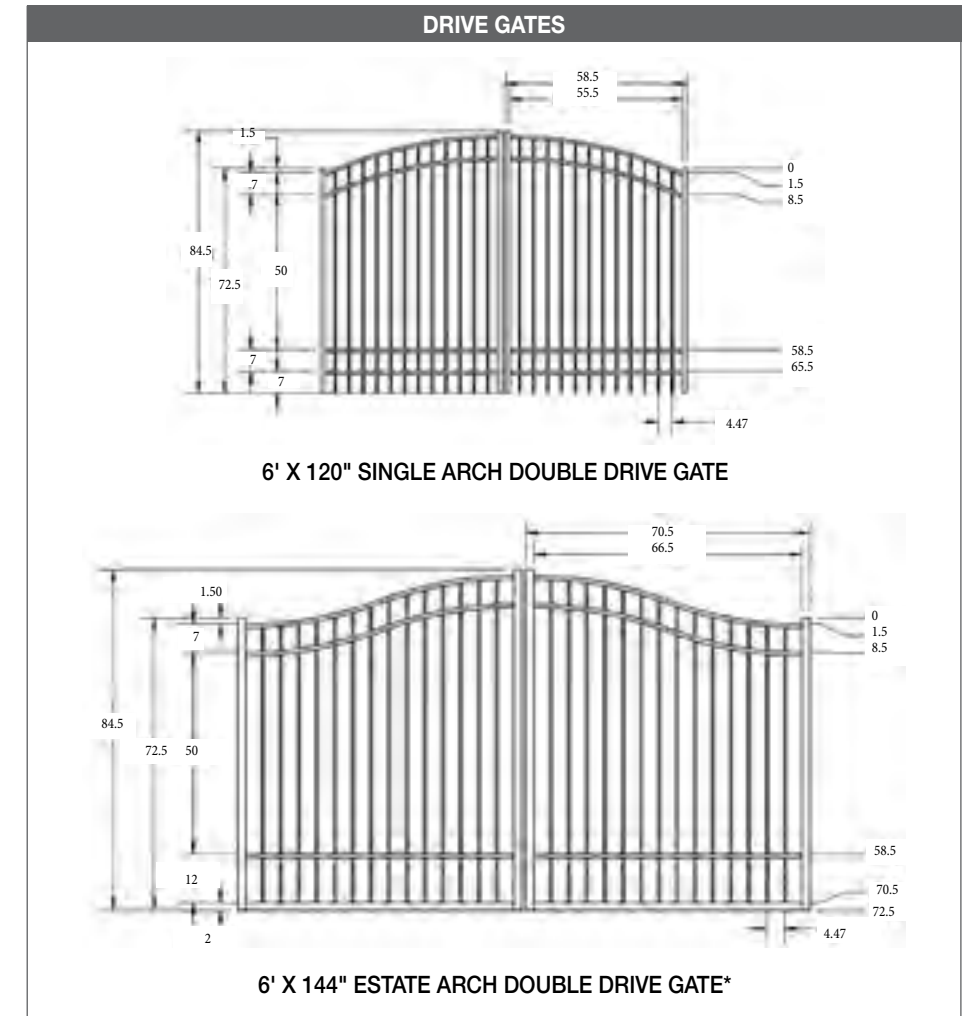
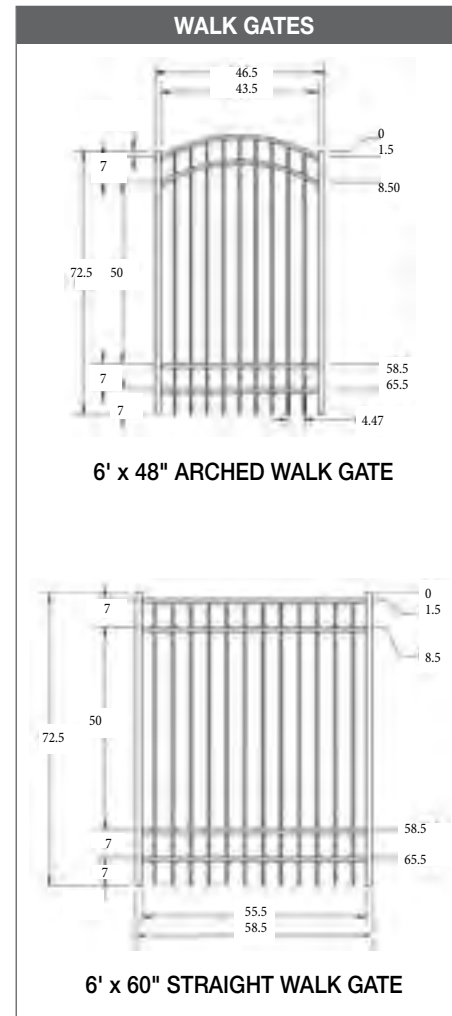
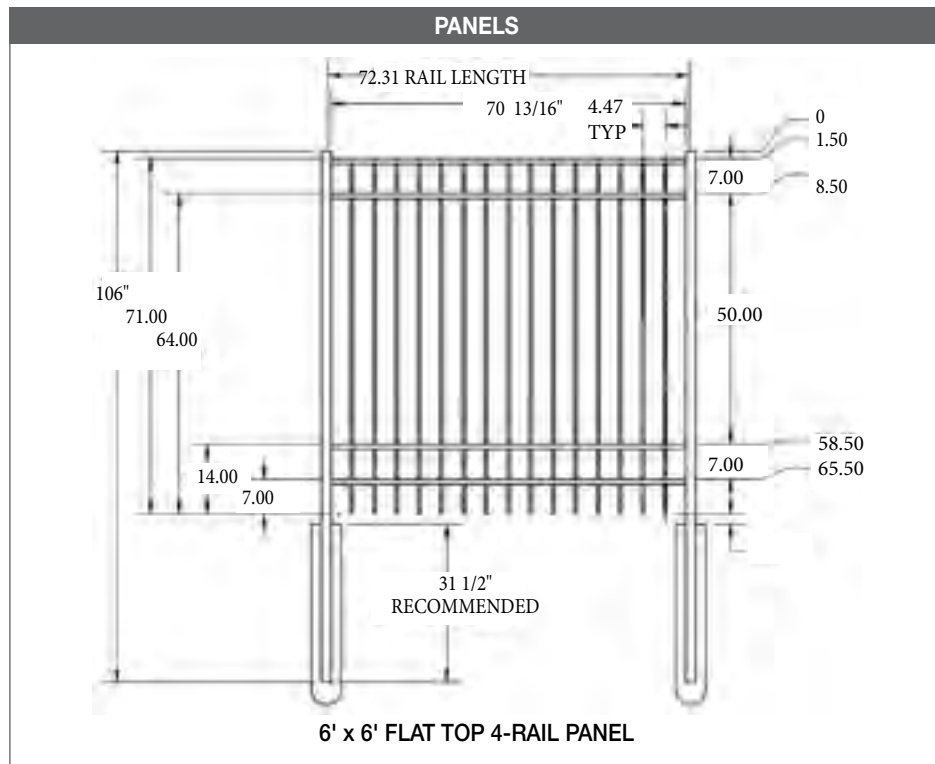

*PLEASE NOTE: For additional strength and stability, all gates beyond 6' wide are built with a thicker bottom frame that creates a flush bottom finish.