



T-TOP RAILING INSTRUCTIONS

Installation Instructions

English..... 1
 Français..... 15
 Español..... 29



Read all instructions prior to installing product.
Refer to manufacturers safety instructions when operating any tools.

To register your product, please visit: barretteoutdoorliving.com

⚠ WARNING:

- Improper installation of this product can result in personal injury. Always wear safety goggles when cutting, drilling and assembling the product.
- Incorrect installation may cause harm to the product or individual.
- Refer to local building codes for installation requirements; failure to install this product in accordance with building codes may affect safety of the product and void product warranty.

NOTICE:

- DO NOT attempt to assemble the kit if parts are missing or damaged.
- DO NOT return the product to the store. For assistance or replacement parts call: 1-877-265-2220.

TOOLS/MATERIALS NEEDED:

Safety Goggles	Power Screwdriver/Drill
Tape Measure	1/8" Drill Bit
Pencil	Power Saw
Level	Straight Edge/Ruler/Triangle

Components list:

Check the packaging to ensure all components are included:

Ref.	Included In Kits	4' Level	5' Level	6' Level	8' Level	10' Level	6' Stair	8' Stair
A	Top Vinyl Rail	1	1	1	1	1	1	1
B	Bottom Vinyl Rail	1	1	1	1	1	1	1
C	Top Aluminum Stiffener*	1	1	1	1	1	1	1
D	Bottom Aluminum Stiffener*	1	1	1	1	1	1	1
E	1½" Balusters (Square/turned)	9	11	13	18	20	12	16
E	¾" Balusters (Round aluminum)	10	13	15	20	26	12	17
F	#10 x 1" Phillips head screw	16	16	16	16	16	16	16
G	#10 x 1.5" Phillips head screw	16	16	16	16	16	16	16
H	Bracket Kit (2 Tops, 2 Bottoms)	1	1	1	1	1	1	1
—	Support Foot	N/A	N/A	N/A	N/A	1	N/A	N/A

*Shape of aluminum will vary depending on length

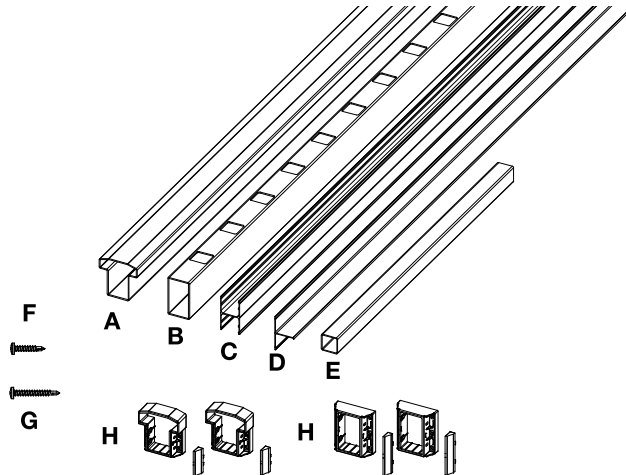

To obtain and review a copy of the warranty please visit barretteoutdoorliving.com.
 You may also contact us at 1-877-265-2220 or email Cs.outdoorliving@barretteoutdoorliving.com.

LEVEL RAIL INSTALLATION

1. Closely follow Post Install Kit installation instructions or use a Post Sleeve over an existing wood 4x4.

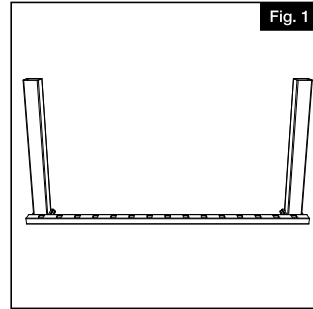

2. CUT RAILS TO LENGTH
 - a. Place bottom rail across post opening leaving equivalent spacing from the last baluster and post on each end (Fig. 1).
 - b. Mark $\frac{1}{8}$ " from end of post to allow room for expansion (Fig. 2).
 - c. Align top rail with bottom rail and cut both rails with miter box or hacksaw (see saw blade manufacturer's specs for correct blade) (Fig. 3).

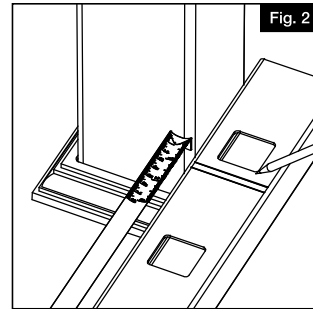

NOTE: You will have to cut through an aluminum insert in each rail.

3. SPACER BLOCKS
Cut two 2" temporary wood spacer blocks (not included) to insert under ends of railing sections to temporarily assist in aligning railing section (Fig. 4).

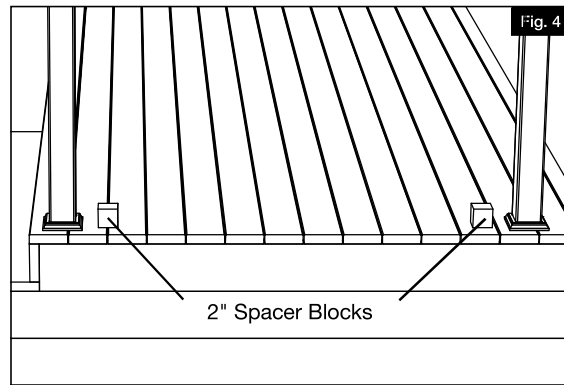
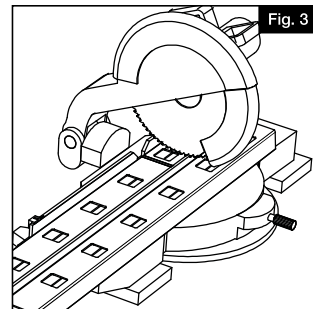

4.

INSTALLING BOTTOM RAIL

NOTE: Fynl Line 10' rail kits include a support foot which should be installed to bottom rail (step a below) prior to attaching rail to brackets.

- a. If installing a 10' kit, locate and mark the center point on the underside (unrouted side) of the bottom rail. Attach the support foot to the bottom rail as shown below (Fig. 5) using supplied set screw.
- b. Place brackets onto both ends of bottom rail (Fig. 6).
- c. Slide bottom rail in between posts and rest on top of wood spacer blocks (Fig. 7).
- d. Ensure bracket is centered to post. Then, using 1/8" drill bit, pre-drill first bottom bracket screw hole through bracket hole and post (use the four outside corner holes) (Fig. 8).
- e. Drive the first #10 x 1 1/2" screw through bottom bracket into post (Fig. 9).
- f. Repeat steps c and d for the remaining three screws for the first bottom bracket.
- g. Repeat steps c, d and e for the second bottom bracket.

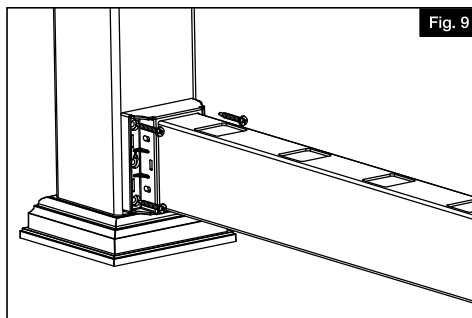
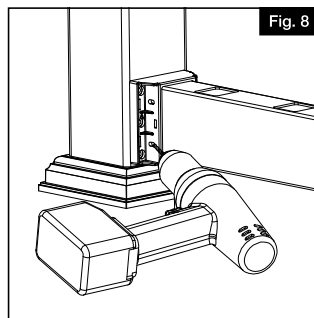
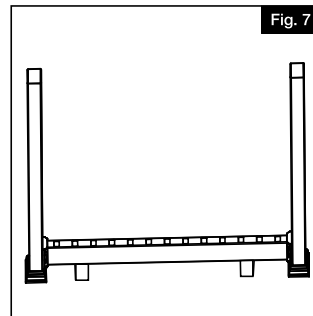
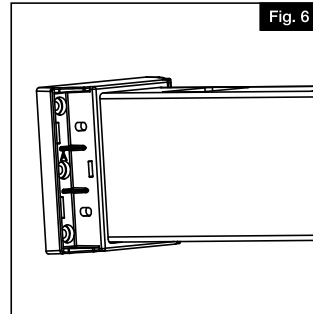
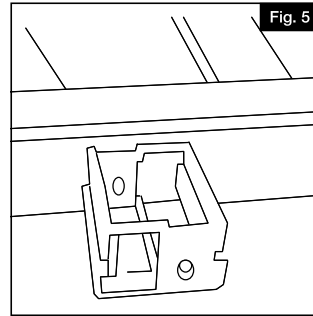

5.

SNAP BALUSTERS INTO YOUR BOTTOM RAIL

- a. Each kit with vinyl balusters contains 2 tabbed balusters. Space them evenly into each section.
- b. Push all balusters into bottom rail (Fig.10).

NOTE: Finyl Line top rails are reinforced with an aluminum channel. Please check the inside of your top rail prior to installation. If it uses a shape other than a capital "H", then be sure to orient that rail so the long part of the aluminum faces the Inside of the deck (Fig. 11).

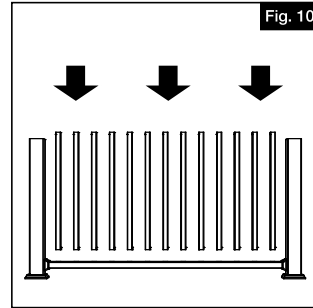

6.

INSTALLING TOP RAIL

- a. Place brackets onto both ends of top rail
- b. Begin at one side of rail and align first baluster with first routed hole on bottom side of top rail and snap top rail into position (Fig. 12).
- c. Continue down the line of balusters installing balusters into top rail.
- d. Install brackets:
 - i. Make sure rails are fully seated with balusters and level and centered to post sleeve. Then, using $\frac{1}{8}$ " drill bit, pre-drill first top bracket screw hole (Fig. 12). Drill through bracket hole, vinyl post sleeve and vinyl insert and loosely install first #10 x $1\frac{1}{2}$ " screw.
 - ii. Repeat pre-drilling process for remaining three screws (Fig. 13).
 - iii. Tighten screws until the bracket is snug with the post. We recommend a non-impact drill with a clutch setting to avoid over tightening (Fig. 14).
 - iv. Repeat steps i-iii for the second top bracket.

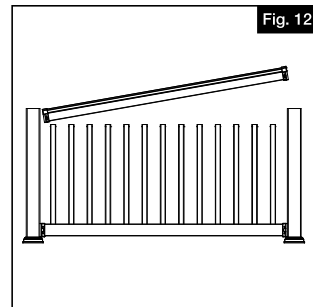
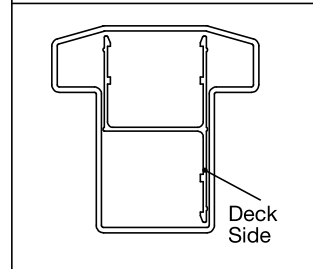
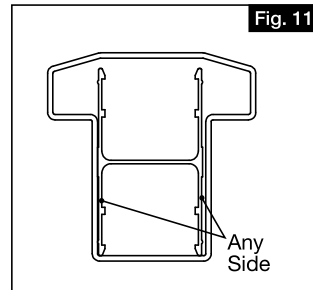

7.

INSTALL SIDE BRACKET SCREWS AND COVERS

- a. For each installed bracket, pre-drill in the center of each elongated hole with a $\frac{1}{8}$ " drill bit (Fig. 15).

NOTE: In some cases you will be drilling through aluminum as well as the vinyl railing.

- b. Install #10 x 1" screws in all pre-drilled holes (Fig. 16).
- c. Match letter on inside of bracket cover to the letter on bracket, and snap cover in place. Repeat for all brackets (Fig. 17).

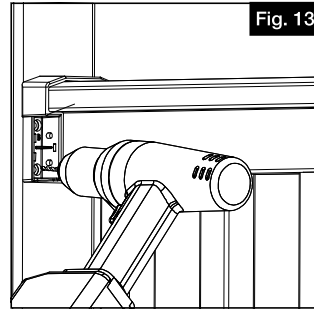

Fig. 13

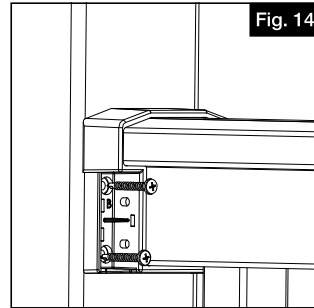

Fig. 14

8.

INSTALL THE SUPPORT FOOT COVER

- a. Attach the support foot to the deck surface using support foot screw and snap the cover into place (10' only) (Fig. 18).

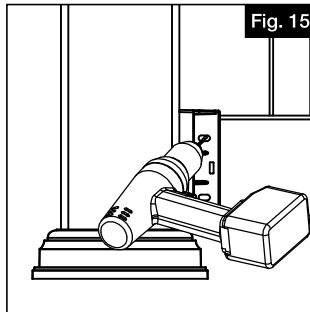

Fig. 15

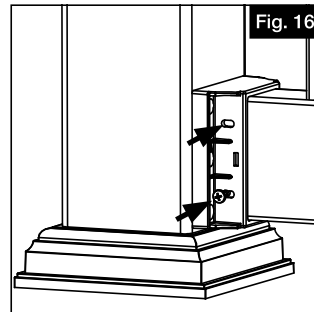

Fig. 16

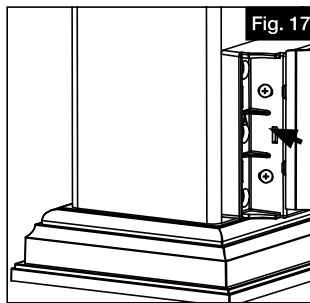

Fig. 17

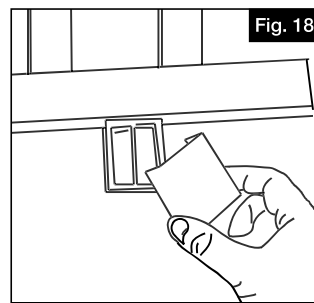

Fig. 18

ANGLED RAIL INSTALLATION

FINYL LINE T-TOP RAILING CAN BE INSTALLED AT ANGLES WITH THREE METHODS/OPTIONS

- I. Using pre-molded adapters (at 22.5° or 45°)
- II. Using adjustable “Swivel” brackets
- III. Using field cut angle brackets

I. 22.5°/45° PRE-MOLDED ADAPTERS

1. Measure distance between post from inside corners (Fig. 1) that will be using the pre-molded adapter and the next post. Subtract $\frac{3}{4}$ " from that distance and that will be the length you will need to cut your top and bottom rails (Fig. 1).
2. Install railing as outlined in level rail section, noting the following:

Place adapter between brackets and posts.
Pre-drill and use the longer 3" screws provided with adapters to connect to the post (Fig. 2).

II. ADJUSTABLE SWIVEL BRACKETS

1. After posts have been installed, determine angle of railing (Fig. 3).

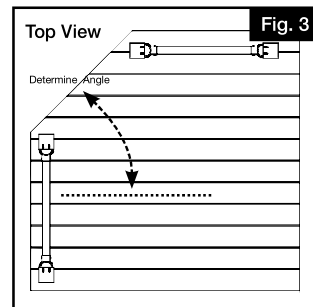
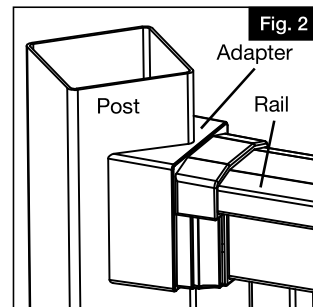
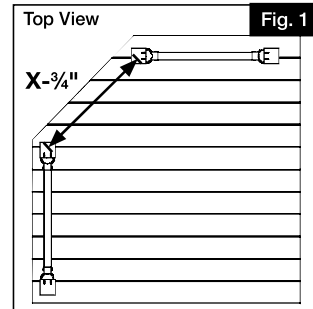

2.

Pre-drill $\frac{1}{8}$ " diameter holes in base, then fasten bracket at the determined angle (Fig. 4).

3.

Cut railing to desired length. Place bracket on each end of top and bottom rails (Fig. 5).

4.

Mark four screw hole locations on each bracket. Set rail section aside, then pre-drill $\frac{1}{8}$ " diameter holes in posts at each mark (Fig. 6).

5.

Attach each top rail bracket with four #10 x 2" screws (Fig. 7). Attach each bottom rail bracket with four #10 x $\frac{1}{2}$ " screws.

6.

Pre-drill one $\frac{1}{8}$ " diameter hole through top rail and aluminum insert for each side of top rail brackets only. Fasten with #10 x 1" flat head screws (Fig. 8).

7.

Add two screw covers for both top and bottom brackets and add two screw caps for each top rail bracket (Fig. 9).

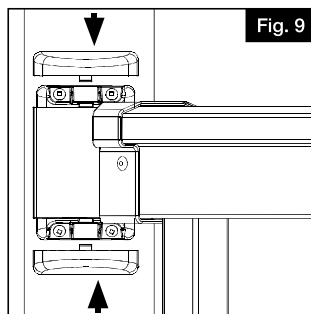
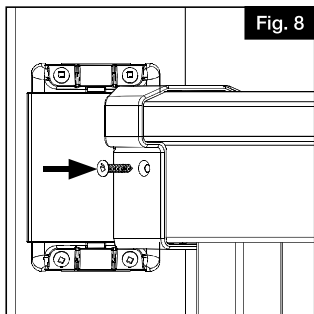
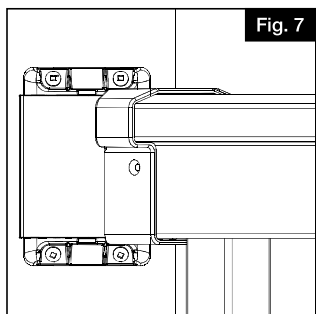
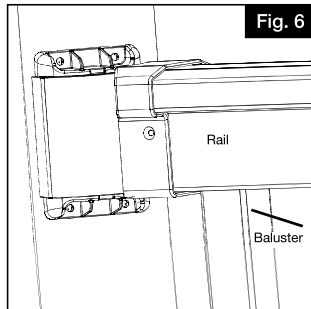
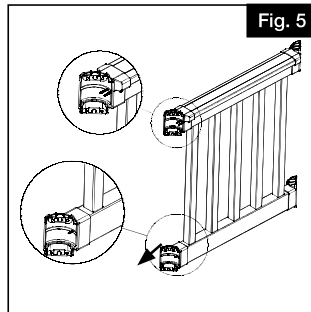
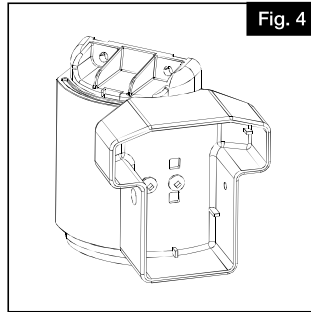

8.

Repeat installation process for each additional rail assembly.

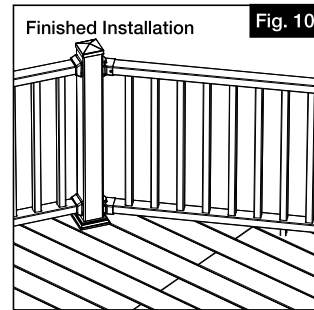

III. FIELD CUT ANGLE BRACKET

1. Slide handrail bracket over ends of railing. Measure angle required, cut bracket and rail (and aluminum channel) to that angle.
2. Repeat for bottom rail.
3. Install railing per instructions for level railing.

NOTE: The maximum cut angle should be no greater than 21.5 degrees to ensure the bracket/rail does not overhang the 4x4 post. If you use this bracket at an angle greater than 21.5 degrees, it is recommended to use a larger post sleeve.

You will want to cut the angle bracket enough to keep your spacing between your post and first baluster at a minimum (4" or less).

Depending on how much the bracket has been cut, a shorter screw may be necessary (to ensure screw does not protrude through the post sleeve).

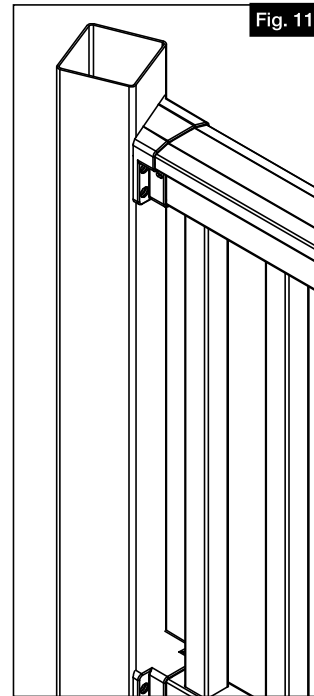

STAIR RAIL INSTALLATION

FINYL LINE T-TOP STAIR RAILING CAN BE INSTALLED WITH THREE METHODS/OPTIONS

- I. Using pre-molded brackets
- II. Using adjustable "Swivel" brackets
- III. Using field cut angle brackets

1.

POST INSTALLATION

Closely follow Post Install Kit installation instructions or use a Post Sleeve on an existing wood 4x4.

2.

DETERMINE SPACING

Temporarily secure a deck board ($\frac{5}{4}$ ") to your stair treads to determine the spacing between the nose of the stairs and your bottom rail (Fig. 1).

NOTE: Finyl Line top rails are reinforced with an aluminum channel. Please check the inside of your top rail prior to installation. If it uses a shape other than a capital "H", then be sure to orient that rail so the long part of the aluminum faces the inside of the deck (Fig. 2).

3.

ASSEMBLE YOUR STAIR RAILING SECTION

- a. Each kit with vinyl balusters contains 2 tabbed balusters. Space them evenly into each section.
- b. Assemble your stair railing section by snapping balusters into bottom rail (Fig. 3).

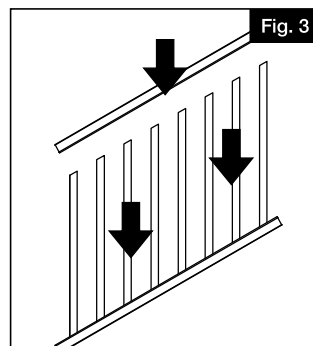
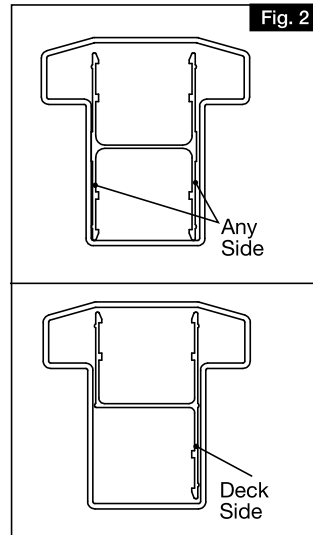
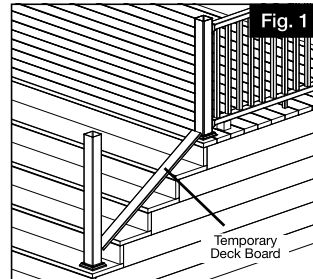

I. USING PRE-MOLDED BRACKETS

1.

STABILIZE SECTION

- Place assembled stair railing section adjacent to mounted stair posts, leaving equal distances from the ends of both balusters and clamp your stair railing section to the posts (Fig. 4).
- Trace the post onto each rail (both ends of top and bottom rails). Make four marks in total being sure to mark $\frac{1}{8}$ " shorter to allow for expansion (Fig. 5).

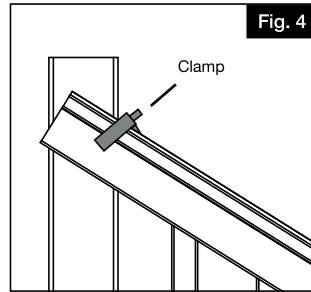

2.

CUTTING RAILS

Remove clamped stair kit from posts. Cut along all four angled marks on rails (Fig. 6).

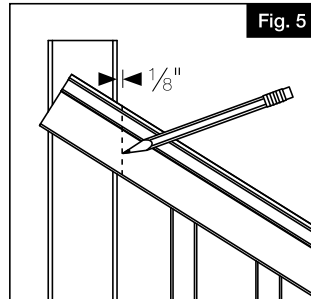

3.

Slide the stair brackets onto the rails (Fig. 7) and place rail section between your posts (Fig. 8).

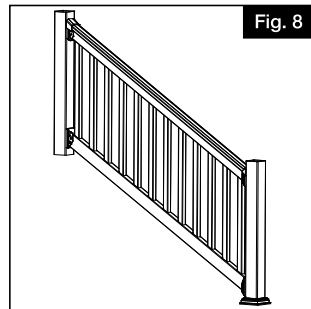
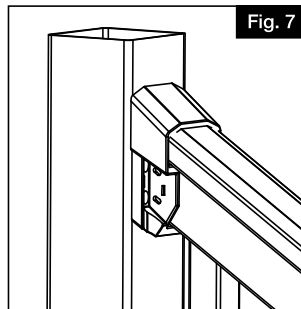
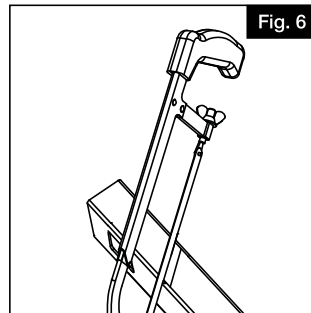

4.

- a. Mark all bracket holes. Pre-drill all bracket holes with $\frac{1}{8}$ " drill bit (Fig. 9).
- b. Drive screws through brackets into post using #10 x $\frac{1}{2}$ " self-tapping square drive screws (4 per bracket) (Fig. 9).

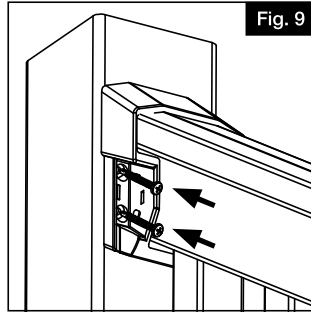

5.

INSTALL SIDE BRACKET SCREWS AND COVERS

For each installed bracket, pre-drill in the center of each elongated hole with a $\frac{1}{8}$ " drill bit (Fig. 10).

NOTE: In some cases you will be drilling through aluminum as well as the vinyl railing.

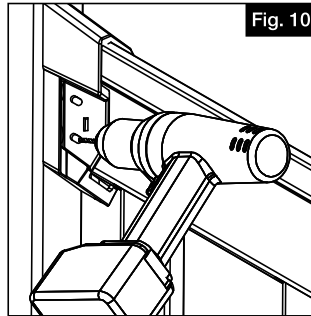

6.

Install #10 x 1" screws in all pre-drilled holes (Fig. 11).

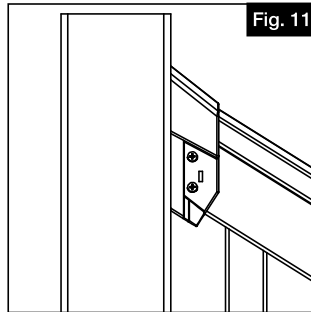

7.

Match letter on inside of bracket cover to the letter on bracket, and snap cover in place (Fig. 12). Repeat for all brackets.

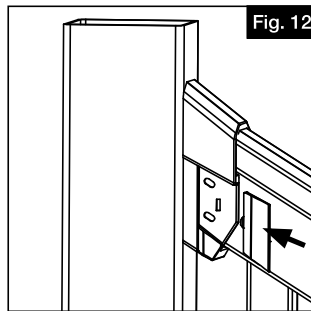

II. ADJUSTABLE SWIVEL BRACKETS

1. After posts have been installed, determine height of bottom rail to stair tread (Fig. 13).

NOTE: 1x6 or 2x4 lumber may be used as a spacer.

2. Assemble rail section. Set rail section on top of spacer and against post. Using a level, hold railing section at proper pitch, then shift section up or down creating equal baluster spacing for each post. After rail is at proper position, hold in place with clamps (Fig. 14).

3. Align Angle Swivel Bracket in position establishing bracket height and the angle rotation of bracket. An additional $\frac{7}{8}$ " will need to be added to length. This second mark will be the cut line for the rail ends. Repeat this step for each end (Fig. 15).

4. After all ends of rails have first mark established, remove clamps from rail assembly. Mark the additional second mark $\frac{7}{8}$ " to rail ends as described in Step 3 and cut rail ends to length.

5. After cutting rail ends, place Angle Swivel Brackets over the ends of each rail. Set rail section back on the spacer between the posts, re-establishing pitch of bracket angle and clamp into position (Fig. 16).

6. Pencil mark the four screw holes in each bracket (Fig. 17). Pencil mark the position that the bracket is at along with the base (Fig. 17).

7. Remove clamps from rail assembly and remove rail assembly from between posts. Pre-drill marked holes from Step 6 into post with a $\frac{1}{8}$ " drill bit.

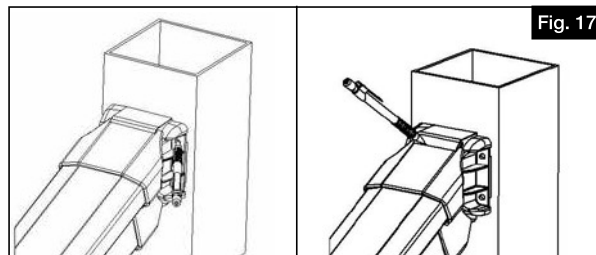
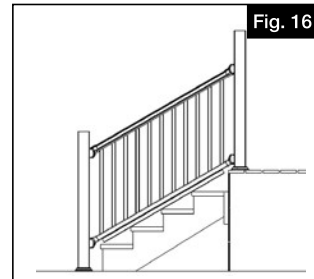
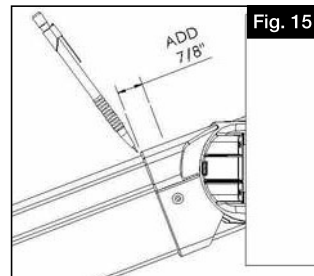
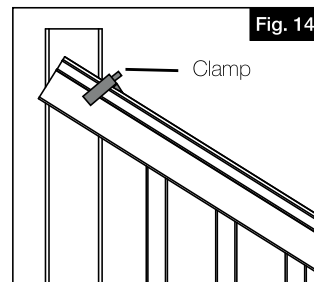
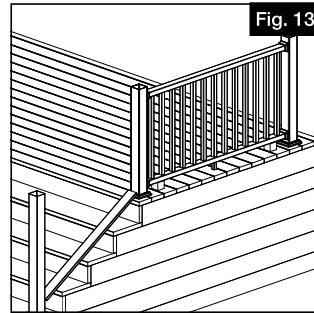

8.

Remove bracket from ends of rail assembly. Aligning bracket and base with the pencil mark from Step 7, fasten with two provided #10 x 1" Pan Head screws (Fig. 18). Bottom bracket uses one #10 x 1" Pan Head screw.

Repeat this for each bracket.

NOTE: Top bracket uses four #10 x 1½" screws, two #10 x 1" flat head screws and two #10 x 1" Pan Head screws.

Bottom bracket uses four #10 x 1½" screws and one #10 x 1" Pan Head screw.

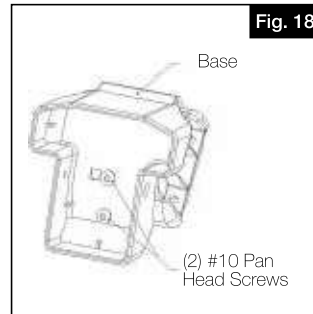

9.

Place brackets back on rail ends, then place rail assembly on spacer (Fig. 19). Fasten brackets to post using four #10 x 1½" screws provided, aligning brackets to pre-drilled holes from Step 8.

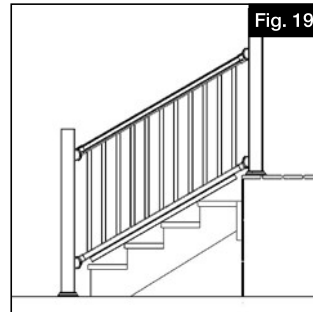

10.

Once all four brackets are fastened to the posts, pre-drill through bracket, rail and aluminum insert (if used) with a 1/8" drill bit, in two places for each bracket. Next, fasten with two supplied #10 x 1" flat head screws (Fig. 20). Repeat this step for each bracket.

Add two screw covers and two screw caps to each bracket.

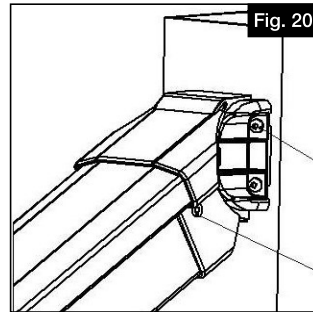

III. FIELD CUT ANGLE BRACKET

1.

a. Slide handrail bracket over ends of railing (Fig. 21). Measure angle required and cut bracket and rail (and aluminum channel) to that angle.

b. Repeat for bottom rail.

c. Install railing per instructions for stair railing.

NOTE: You will want to cut the angle bracket enough to keep your spacing between your post and first baluster at a minimum (4" or less).

